



**600 / 400 / 150 litre series
Refrigerators/Freezers**

Instruction manual



Model:

**CD080-A/CD081-A/CD082-A/CD083-A/CD084-A/CD085-A/CD610-A/CD611-A/CD612-A/
CD613-A/CD614-A/CD615-A/CD086-A/CD087-A/CD088-A/CB921-A/GL185-A**

Safety Instructions

- Position on a flat, stable surface.
- A service agent/qualified technician should carry out installation and any repairs if required. Do not remove any components or service panels on this product.
 - **In Queensland the service agent/qualified technician MUST hold a Gas Work Authorisation or License for hydrocarbon refrigerants if the appliance gas system is being opened or charged.**
- Consult Local and National Standards to comply with the following:
 - Health and Safety at Work Legislation
 - Fire Precautions
 - Wiring Regulations
 - Building Regulations
- DO NOT use jet/pressure washers to clean the appliance.
- DO NOT use the appliance outside.
- DO NOT use this appliance to store medical supplies.
- DO NOT allow oil or fat to come into contact with the plastic components or door seal. Clean immediately if contact occurs.
- DO NOT store products on top of the appliance.
- Bottles that contain a high percentage of alcohol must be sealed and placed vertically in the refrigerator.
- Always carry, store and handle the appliance in a vertical position and move by holding the base of the appliance.
- Always switch off and disconnect the power supply to the unit before cleaning.
- Keep all packaging away from children. Dispose of the packaging in accordance with the regulations of local authorities.
- If the power cord is damaged, it must be replaced by a POLAR agent or a recommended qualified technician in order to avoid a hazard.
- Children should be supervised to ensure that they do not play with the appliance.

- This appliance is not intended for use by persons (including children) with reduced physical, sensory or mental capabilities, or lack of experience or knowledge, unless they have been given supervision or instruction concerning the use of the appliance by a person responsible for their safety.
- POLAR recommend that this appliance should be periodically tested (at least annually) by a Competent Person. Testing should include, but not be limited to: Visual Inspection, Polarity Test, Earth Continuity, Insulation Continuity and Functional Testing.

Caution: Risk of Fire

- Do not store explosive substances such as aerosol cans with a flammable propellant in this appliance.



Warning: Keep all ventilation openings clear of obstruction. Unit should not be boxed in without adequate ventilation.

- **To comply with AS/NZS 60079.10.1:2009: Ensure there are not sources of ignition in any area where refrigerant could gather in the event of a leak.**
- **Electrical equipment should not be placed under the vent or where refrigerant could gather in the event of a leak.**
- **Warning:** Do not use mechanical devices or other means to accelerate the defrosting process, other than those recommended by the manufacturer.
- **Warning:** Do not damage the refrigerant circuit.
- **Warning:** Do not use electrical appliances inside the food storage compartments of the appliance.

Product Description

- | | |
|---|---|
| • CD080-A - 150 litre Refrigerator | • CD613-A - 365 litre Freezer |
| • CD081-A - 140 litre Freezer | • CD614-A - 600 litre Refrigerator |
| • CD082-A - 400 litre Refrigerator | • CD615-A - 600 litre Freezer |
| • CD083-A - 365 litre Freezer | • CD610-A - 150 litre Refrigerator |
| • CD084-A - 600 litre Refrigerator | • CD611-A - 140 litre Freezer |
| • CD085-A - 600 litre Freezer | • CD612-A - 400 litre Refrigerator |
| • CD086-A - 150 litre Glass-Door Refrigerator | • GL185-A - 522 litre Bakery Refrigerator |
| • CD087-A - 400 litre Glass-Door Refrigerator | • CB921-A - 365 litre Glass-Door Freezer |
| • CD088-A - 600 litre Glass-Door Refrigerator | |

Introduction

Please take a few moments to carefully read through this manual. Correct maintenance and operation of this machine will provide the best possible performance from your POLAR product.

Pack Contents

The following is included:

- POLAR Refrigerator / Freezer
- Shelves - Refrigerator only
CD610-A/ CD080-A x 3/ CD086-A x 3
CD612-A/ CD082-A x 4 / CD087-A x 4
CD614-A x 4 / CD084-A / CD088-A x 4
- Tray Guides - Bakery refrigerator only
GL185-A x 12
- Keys x 2
- Spacers x 2
- Instruction Manual
- Door handle assembly

POLAR prides itself on quality and service, ensuring that at the time of unpacking the contents are supplied fully functional and free of damage.

Should you find any damage as a result of transit, please contact your POLAR dealer immediately.

Installation

Note: A bracket is used to support the door during transportation. On receipt please remove the bracket.

Note: Not for use in vans or trailers, food trucks or similar vehicles.

If the unit has not been stored or moved in an upright position, let it stand upright for approximately 12 hours before operation. If in doubt allow to stand.

1. Remove the appliance from the packaging. Make sure that all protective plastic film and coatings are thoroughly removed from all surfaces.
2. To optimize performance and longevity, ensure a minimum clearance of 2.5cm is maintained between the unit and walls and other objects, with a minimum 20cm clearance on the top. **NEVER LOCATE NEXT TO A HEAT SOURCE.**



Note: Before using the appliance for the first time, clean the shelves and interior with soapy water then dry well.

The appliance is supplied with feet by default. However, castors can be supplied as an option.

Mounting the door handle (For model CD086-A, CD087-A, CD088-A, CB921-A only)

1. Pull the door gasket aside to expose the 2 pre-drilled holes. Insert the screws.
2. Mount sleeve on the other end of screw. Tighten screws to fix the handle in place.

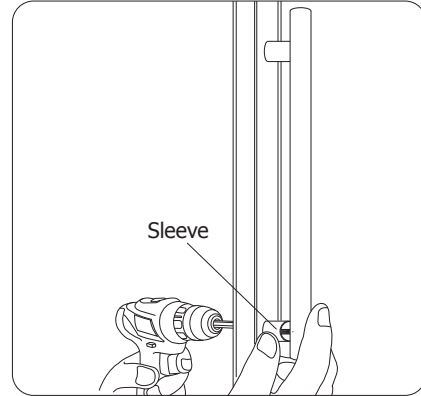
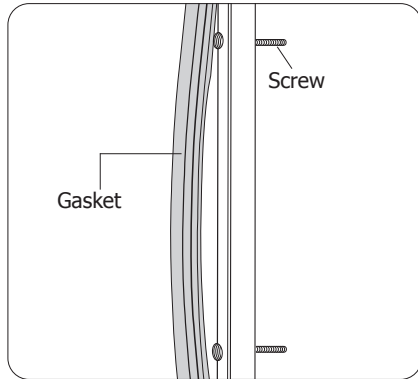

Reversing the door (Excluding model CB921-A)

Depending on the location of the appliance, it may be necessary to change the direction the door opens by changing the side of the door handle. (Tip: Images in this section are for illustration only and may slightly differ from the actual appliance appearances.)

To reverse the door handle:

1. The door handle is on the left side. Disassemble the right lower hinge.

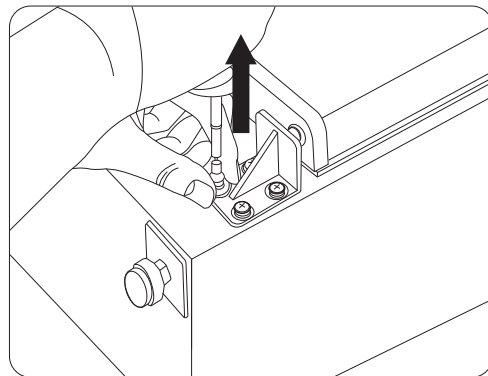
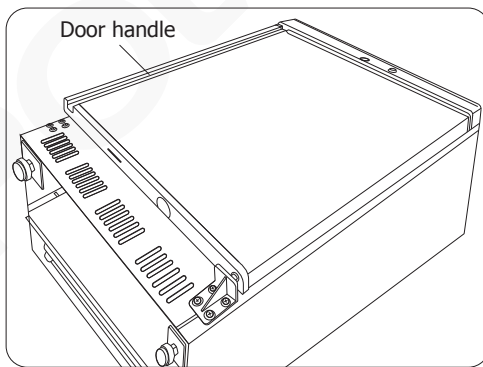

2. Remove the door from the right upper hinge. Then remove the hinge sleeve from the door top.

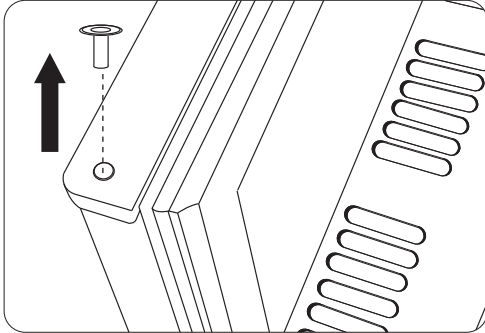

4. Reverse the door and hang it onto the left upper hinge.

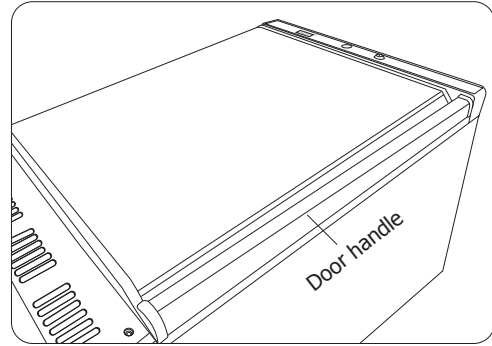

3. Remove the right upper hinge and install it on the left side. Afterwards, install the hinge sleeve onto the hinge.

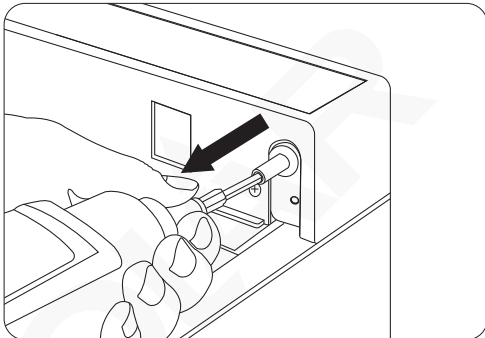

5. Remove the pre-mounted screws on the left lower side.

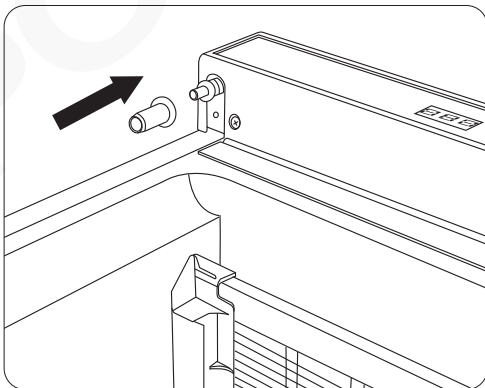
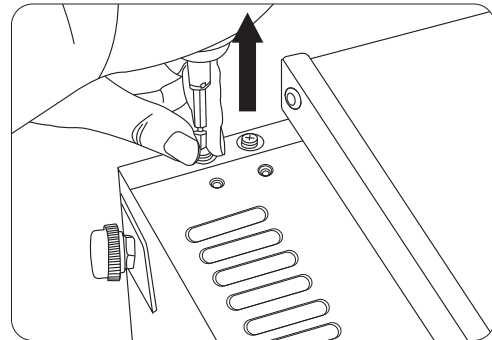

6. Install the previously removed right lower hinge on the left side.

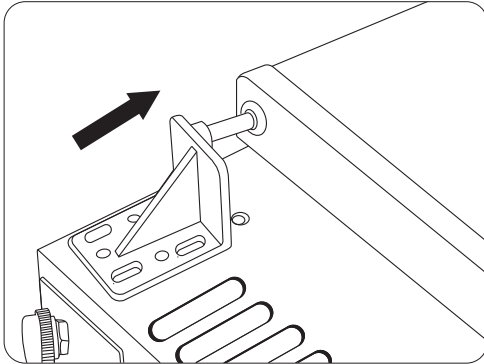

7. Secure the hinge in place using the previously removed screws.

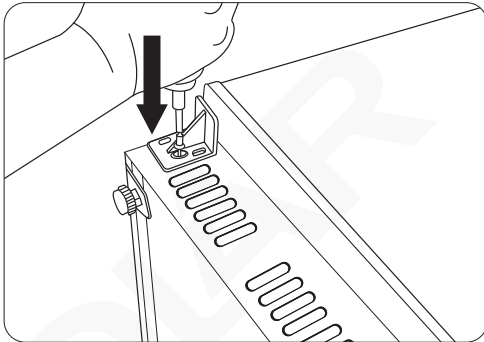

8. Now the door handle is installed on the right side.

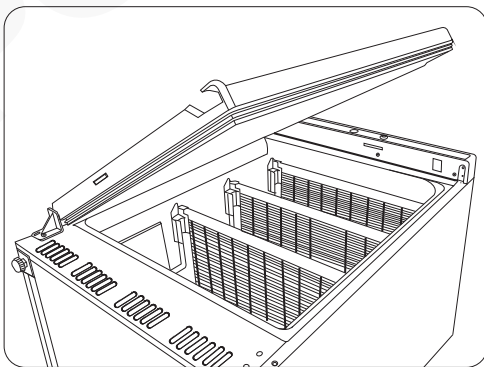

Operation

Control Panel

The control panel is located on the front of the appliance.

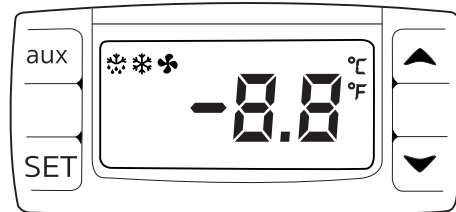

Turn On

1. Close the door of the appliance.
2. Connect the appliance to a mains power supply.

Set the Operating Temperature

1. Press the **SET** button for 3 seconds. The display will flash.
2. Press the ▲ or ▼ buttons to display the required temperature.
3. Press the **SET** button to store the temperature.

Manual Defrost

Press and hold the defrost button "aux" for 2 seconds to begin a manual defrost. The defrost light illuminates.

The defrost cycle will end automatically.

Storing Food

To get the best results from your POLAR appliance, follow these instructions:

- Only store foodstuffs in the appliance when it has reached the correct operating temperature.
- Do not place uncovered items as below inside the appliance, as this can lead to a damaged and leaking evaporator, and thus void your warranty: hot food, hot liquids, acidic fluids, acidic products.
- Wrap or cover food where possible.
- Do not obstruct the fans inside the appliance.
- Avoid opening the doors for prolonged periods of time.

Lock/Unlock the Doors

- A lock is fitted to the doors to ensure foodstuffs are kept secure within your POLAR appliance.
- Use the keys provided to lock/unlock the door.

Cleaning, Care & Maintenance

- Switch off and disconnect from the power supply before cleaning.
- Clean the interior of the appliance as often as possible.
- Do not use abrasive cleaning agents. These can leave harmful residues.
- Clean the door seal with warm soapy water.
- Always wipe dry after cleaning.
- Do not allow water used in cleaning to run through the drain hole into the evaporation pan.
- Take care when cleaning the rear of the appliance. Sharp edges can cut.

Refrigerating tips:

- Condensation and ice will form with frequent and prolonged opening of the doors.
- Operating outside of the recommend temperature range and placing next to a heat source will also increase the amount of ice and internal/external condensation. If external condensation occurs wipe the surface down with a cloth.
- Excessive ice will result in longer running times that will increase energy consumption and increase the deterioration of components.
- If the gasket or seal is damaged or deformed, energy consumption will increase. To restore efficiency, replace gasket.
- Do not obstruct fans and do not exceed max load lines, as doing so will impact air distribution and increase energy usage.

Cleaning the Condenser

Periodically cleaning the condenser can extend the life of the appliance.

POLAR recommend that a POLAR agent or qualified technician should clean the condenser.

Failure to clean the condenser will increase energy consumption, reduce the performance and life of your Polar unit, and thus may invalidate your warranty.

Troubleshooting

A qualified technician must carry out repairs if required.

Fault	Probable Cause	Solution
The appliance is not working	The unit is not switched on	Check the unit is plugged in correctly and switched on
	Plug or lead is damaged	Replace Plug or lead
	Mains power supply fault	Check mains power supply
The appliance turns on, but the temperature is too high/low	Too much ice on the evaporator	Defrost the appliance
	Condenser blocked with dust	Clean the condenser
	Doors are not shut properly	Check doors are shut and seals are not damaged
	Appliance is located near a heat source or air flow to the condenser is being interrupted	Move the refrigerator to a more suitable location
	Ambient temperature is too high	Increase ventilation or move appliance to a cooler position
	Unsuitable foodstuffs are being stored in the appliance	Remove any excessive hot foodstuffs or blockages to the fan
	Appliance is overloaded	Reduce the amount of food stored in the appliance
The appliance is leaking water	The appliance is not properly levelled	Adjust the screw feet to level the appliance (if applicable)
	The discharge outlet is blocked	Clear the discharge outlet

Fault	Probable Cause	Solution
The appliance is leaking water	Movement of water to the drain is obstructed	Clear the floor of the appliance (if applicable)
	The water container is damaged	Consult a qualified Technician
The appliance is unusually loud	Loose nut/screw	Check and tighten all nuts and screws
	The appliance has not been installed in a level or stable position	Check installation position and change if necessary
The lamp does not illuminate	Lamp needing replacing	Consult a qualified Technician

Electrical Wiring

The plug is to be connected to a suitable mains socket.

POLAR appliances are wired as follows:

- Live wire (coloured brown) to terminal marked L
- Neutral wire (coloured blue) to terminal marked N
- Earth wire (coloured green/yellow) to terminal marked E

This appliance must be earthed.



If in doubt consult a qualified electrician.

Electrical isolation points must be kept clear of any obstructions. In the event of any emergency disconnection being required they must be readily accessible.

Compliance

The WEEE logo on this product or its documentation indicates that the product must not be disposed of as household waste. To help prevent possible harm to human health and/or the environment, the product must be disposed of in an approved and environmentally safe recycling process. For further information on how to dispose of this product correctly, contact the product supplier, or the local authority responsible for waste disposal in your area.

POLAR parts have undergone strict product testing in order to comply with regulatory standards and specifications set by international, independent, and federal authorities.

POLAR products have been approved to carry the following symbol:



All rights reserved. No part of these instructions may be produced or transmitted in any form or by any means, electronic, mechanical, photocopying, recording or otherwise, without the prior written permission of POLAR.

Every effort is made to ensure all details are correct at the time of going to press, however, POLAR reserve the right to change specifications without notice.

Information requirements for professional refrigerated storage cabinets

Note: Due to our continuous improvement process, the product specifications are subject to change without notice.

EN	Model(s): [information identifying the model(s) to which the information relates]		CD610-A
EN	Intended use	Storage	Category - Vertical/counter Vertical
EN	Operating temperature(s) - chilled/frozen/multi-use		Chilled: -2°C ~ 8°C
EN	(where applicable) Heavy-duty/light-duty	Light Duty	
EN	Refrigerant fluid(s): [information to identify the refrigerant fluid(s), including GWP]		R600a/ GWP 3
	V / Hz	H x W x D	Kg
	220-240V~ 50Hz	855 x 600 x 595mm	44kg

Note: For optimal product performance and efficiency, please ensure to mind the net usable capacity (load limit) when filling.

	CD610-A	CD610-A-02			
EN	Annual Energy Consumption AEC (kWh)	409	361		
EN	Energy Efficiency Index EEI	20.9	18.4		
EN	Net volume Vn litre (where applicable)	64L	64L		
EN	Chilled volume Vn Ref litre	64L	64L		
EN	Frozen volume Vn Frz litre	N/A	N/A		
EN	Refrigerant charge x.xx kg	0.035kg	0.035kg		
EN	Power / Current	100W/ 0.7A	100W/ 0.7A		

Information requirements for professional refrigerated storage cabinets

Note: Due to our continuous improvement process, the product specifications are subject to change without notice.

EN	Model(s): [information identifying the model(s) to which the information relates]		CD080-A
EN	Intended use	Storage	Category - Vertical/counter Vertical
EN	Operating temperature(s) - chilled/frozen/multi-use		Chilled: -2°C ~ 8°C
EN	(where applicable) Heavy-duty/light-duty	Light Duty	
EN	Refrigerant fluid(s): [information to identify the refrigerant fluid(s), including GWP]		R600a/ GWP 3
	V / Hz	H x W x D	Kg
	220-240V~ 50Hz	855 x 600 x 595mm	44kg

Note: For optimal product performance and efficiency, please ensure to mind the net usable capacity (load limit) when filling.

	CD080-A	CD080-A-02			
EN	Annual Energy Consumption AEC (kWh)	409	361		
EN	Energy Efficiency Index EEI	20.9	18.4		
EN	Net volume Vn litre (where applicable)	64L	64L		
EN	Chilled volume Vn Ref litre	64L	64L		
EN	Frozen volume Vn Frz litre	N/A	N/A		
EN	Refrigerant charge x.xx kg	0.035kg	0.035kg		
EN	Power / Current	100W/ 0.7A	100W/ 0.7A		

Information requirements for professional refrigerated storage cabinets

Note: Due to our continuous improvement process, the product specifications are subject to change without notice.

EN	Model(s): [information identifying the model(s) to which the information relates]	CD611-A
EN	Intended use	Storage
	Category - Vertical/counter	Vertical
EN	Operating temperature(s) - chilled/frozen/multi-use	Frozen: -10°C ~ -25°C
EN	(where applicable) Heavy-duty/light-duty	Light Duty
EN	Refrigerant fluid(s): [information to identify the refrigerant fluid(s), including GWP]	R600a/ GWP 3

V / Hz	H x W x D	Kg
220-240V~ 50Hz	855 x 600 x 595mm	44.5kg

Note: For optimal product performance and efficiency, please ensure to mind the net usable capacity (load limit) when filling.

	CD611-A				
EN	Annual Energy Consumption AEC (kWh)	511			
EN	Energy Efficiency Index EEI	18.0			
EN	Net volume Vn litre (where applicable)	78L			
EN	Chilled volume Vn Ref litre	N/A			
EN	Frozen volume Vn Frz litre	78L			
EN	Refrigerant charge x.xx kg	0.060kg			
EN	Power / Current	105W/ 0.8A			

Information requirements for professional refrigerated storage cabinets

Note: Due to our continuous improvement process, the product specifications are subject to change without notice.

EN	Model(s): [information identifying the model(s) to which the information relates]	CD081-A
EN	Intended use	Storage
	Category - Vertical/counter	Vertical
EN	Operating temperature(s) - chilled/frozen/multi-use	Frozen: -10°C ~ -25°C
EN	(where applicable) Heavy-duty/light-duty	Light Duty
EN	Refrigerant fluid(s): [information to identify the refrigerant fluid(s), including GWP]	R600a/ GWP 3

V / Hz	H x W x D	Kg
220-240V~ 50Hz	855 x 600 x 595mm	44.5kg

Note: For optimal product performance and efficiency, please ensure to mind the net usable capacity (load limit) when filling.

	CD081-A				
EN	Annual Energy Consumption AEC (kWh)	511			
EN	Energy Efficiency Index EEI	18.0			
EN	Net volume Vn litre (where applicable)	78L			
EN	Chilled volume Vn Ref litre	N/A			
EN	Frozen volume Vn Frz litre	78L			
EN	Refrigerant charge x.xx kg	0.060kg			
EN	Power / Current	105W/ 0.8A			

Information requirements for professional refrigerated storage cabinets

Note: Due to our continuous improvement process, the product specifications are subject to change without notice.

EN	Model(s): [information identifying the model(s) to which the information relates]	CD612-A
EN	Intended use	Storage
	Category - Vertical/counter	Vertical
EN	Operating temperature(s) - chilled/frozen/multi-use	Chilled: -2°C ~ 8°C
EN	(where applicable) Heavy-duty/light-duty	Light Duty
EN	Refrigerant fluid(s): [information to identify the refrigerant fluid(s), including GWP]	R600a/ GWP 3

V / Hz	H x W x D	Kg
220-240V~ 50Hz	1855 x 600 x 595mm	69kg

Note: For optimal product performance and efficiency, please ensure to mind the net usable capacity (load limit) when filling.

	CD612-A	CD612-A-02	CD612-A-03		
EN	Annual Energy Consumption AEC (kWh)	478	489	460	
EN	Energy Efficiency Index EEI	47.8	48.7	45.9	
EN	Net volume Vn litre (where applicable)	238L	238L	238L	
EN	Chilled volume Vn Ref litre	238L	238L	238L	
EN	Frozen volume Vn Frz litre	N/A	N/A	N/A	
EN	Refrigerant charge x.xx kg	0.075kg	0.075kg	0.075kg	
EN	Power / Current	130W/ 0.8A	130W/ 0.8A	130W/ 0.8A	

Information requirements for professional refrigerated storage cabinets

Note: Due to our continuous improvement process, the product specifications are subject to change without notice.

EN	Model(s): [information identifying the model(s) to which the information relates]	CD082-A
EN	Intended use	Storage
	Category - Vertical/counter	Vertical
EN	Operating temperature(s) - chilled/frozen/multi-use	Chilled: -2°C ~ 8°C
EN	(where applicable) Heavy-duty/light-duty	Light Duty
EN	Refrigerant fluid(s): [information to identify the refrigerant fluid(s), including GWP]	R600a/ GWP 3

V / Hz	H x W x D	Kg
220-240V~ 50Hz	1855 x 600 x 595mm	69kg

Note: For optimal product performance and efficiency, please ensure to mind the net usable capacity (load limit) when filling.

	CD082-A	CD082-A-02	CD082-A-03		
EN	Annual Energy Consumption AEC (kWh)	478	489	460	
EN	Energy Efficiency Index EEI	47.8	48.7	45.9	
EN	Net volume Vn litre (where applicable)	238L	238L	238L	
EN	Chilled volume Vn Ref litre	238L	238L	238L	
EN	Frozen volume Vn Frz litre	N/A	N/A	N/A	
EN	Refrigerant charge x.xx kg	0.075kg	0.075kg	0.075kg	
EN	Power / Current	130W/ 0.8A	130W/ 0.8A	130W/ 0.8A	

Information requirements for professional refrigerated storage cabinets

Note: Due to our continuous improvement process, the product specifications are subject to change without notice.

EN	Model(s): [information identifying the model(s) to which the information relates]	CD613-A
EN	Intended use	Storage
	Category - Vertical/counter	Vertical
EN	Operating temperature(s) - chilled/frozen/multi-use	Frozen: -10°C ~ -25°C
EN	(where applicable) Heavy-duty/light-duty	Light Duty
EN	Refrigerant fluid(s): [information to identify the refrigerant fluid(s), including GWP]	R600a/ GWP 3

V / Hz	H x W x D	Kg
220-240V~ 50Hz	1855 x 600 x 595mm	71kg

Note: For optimal product performance and efficiency, please ensure to mind the net usable capacity (load limit) when filling.

		CD613-A			
EN	Annual Energy Consumption AEC (kWh)	894			
EN	Energy Efficiency Index EEI	32.6			
EN	Net volume Vn litre (where applicable)	258L			
EN	Chilled volume Vn Ref litre	N/A			
EN	Frozen volume Vn Frz litre	258L			
EN	Refrigerant charge x.xx kg	0.090kg			
EN	Power / Current	150W/ 0.9A			

Information requirements for professional refrigerated storage cabinets

Note: Due to our continuous improvement process, the product specifications are subject to change without notice.

EN	Model(s): [information identifying the model(s) to which the information relates]	CD083-A
EN	Intended use	Storage
	Category - Vertical/counter	Vertical
EN	Operating temperature(s) - chilled/frozen/multi-use	Frozen: -10°C ~ -25°C
EN	(where applicable) Heavy-duty/light-duty	Light Duty
EN	Refrigerant fluid(s): [information to identify the refrigerant fluid(s), including GWP]	R600a/ GWP 3

V / Hz	H x W x D	Kg
220-240V~ 50Hz	1855 x 600 x 595mm	71kg

Note: For optimal product performance and efficiency, please ensure to mind the net usable capacity (load limit) when filling.

		CD083-A			
EN	Annual Energy Consumption AEC (kWh)	894			
EN	Energy Efficiency Index EEI	32.6			
EN	Net volume Vn litre (where applicable)	258L			
EN	Chilled volume Vn Ref litre	N/A			
EN	Frozen volume Vn Frz litre	258L			
EN	Refrigerant charge x.xx kg	0.090kg			
EN	Power / Current	150W/ 0.9A			

Information requirements for professional refrigerated storage cabinets

Note: Due to our continuous improvement process, the product specifications are subject to change without notice.

EN	Model(s): [information identifying the model(s) to which the information relates]			CD614-A
EN	Intended use	Storage	Category - Vertical/counter	Vertical
EN	Operating temperature(s) - chilled/frozen/multi-use			Chilled: -2°C ~ 8°C
EN	(where applicable) Heavy-duty/light-duty		Light Duty	
EN	Refrigerant fluid(s): [information to identify the refrigerant fluid(s), including GWP]			R600a/ GWP 3
	V / Hz	H x W x D	Kg	
	220-240V~ 50Hz	1895 x 777 x 705mm	90kg	

Note: For optimal product performance and efficiency, please ensure to mind the net usable capacity (load limit) when filling.

		CD614-A	CD614-A-02	CD614-A-03	CD614-A-04	
EN	Annual Energy Consumption AEC (kWh)	N/A	672	697	577	
EN	Energy Efficiency Index EEI	N/A	51.8	53.1	43.9	
EN	Net volume Vn litre (where applicable)	419L	419L	419L	419L	
EN	Chilled volume Vn Ref litre	419L	419L	419L	419L	
EN	Frozen volume Vn Frz litre	N/A	N/A	N/A	N/A	
EN	Refrigerant charge x.xx kg	0.100kg	0.100kg	0.100kg	0.100kg	
EN	Power / Current	130W/ 0.9A	130W/ 0.9A	130W/ 0.9A	130W/ 0.9A	

Information requirements for professional refrigerated storage cabinets

Note: Due to our continuous improvement process, the product specifications are subject to change without notice.

EN	Model(s): [information identifying the model(s) to which the information relates]			CD084-A
EN	Intended use	Storage	Category - Vertical/counter	Vertical
EN	Operating temperature(s) - chilled/frozen/multi-use			Chilled: -2°C ~ 8°C
EN	(where applicable) Heavy-duty/light-duty		Light Duty	
EN	Refrigerant fluid(s): [information to identify the refrigerant fluid(s), including GWP]			R600a/ GWP 3
	V / Hz	H x W x D	Kg	
	220-240V~ 50Hz	1895 x 777 x 705mm	90kg	

Note: For optimal product performance and efficiency, please ensure to mind the net usable capacity (load limit) when filling.

		CD084-A	CD084-A-02	CD084-A-03	CD084-A-04	
EN	Annual Energy Consumption AEC (kWh)	N/A	672	697	577	
EN	Energy Efficiency Index EEI	N/A	51.8	53.1	43.9	
EN	Net volume Vn litre (where applicable)	419L	419L	419L	419L	
EN	Chilled volume Vn Ref litre	419L	419L	419L	419L	
EN	Frozen volume Vn Frz litre	N/A	N/A	N/A	N/A	
EN	Refrigerant charge x.xx kg	0.100kg	0.100kg	0.100kg	0.100kg	
EN	Power / Current	130W/ 0.9A	130W/ 0.9A	130W/ 0.9A	130W/ 0.9A	

Information requirements for professional refrigerated storage cabinets

Note: Due to our continuous improvement process, the product specifications are subject to change without notice.

EN	Model(s): [information identifying the model(s) to which the information relates]	CD615-A
EN	Intended use	Storage
	Category - Vertical/counter	Vertical
EN	Operating temperature(s) - chilled/frozen/multi-use	Frozen: -10°C ~ -25°C
EN	(where applicable) Heavy-duty/light-duty	Light Duty
EN	Refrigerant fluid(s): [information to identify the refrigerant fluid(s), including GWP]	R600a/ GWP 3

V / Hz	H x W x D	Kg
220-240V~ 50Hz	1890 x 777 x 705mm	94kg

Note: For optimal product performance and efficiency, please ensure to mind the net usable capacity (load limit) when filling.

	CD615-A				
EN	Annual Energy Consumption AEC (kWh)	989			
EN	Energy Efficiency Index EEI	26.1			
EN	Net volume Vn litre (where applicable)	469L			
EN	Chilled volume Vn Ref litre	N/A			
EN	Frozen volume Vn Frz litre	469L			
EN	Refrigerant charge x.xx kg	0.150kg			
EN	Power / Current	300W/ 1.4A			

Information requirements for professional refrigerated storage cabinets

Note: Due to our continuous improvement process, the product specifications are subject to change without notice.

EN	Model(s): [information identifying the model(s) to which the information relates]	CD085-A
EN	Intended use	Storage
	Category - Vertical/counter	Vertical
EN	Operating temperature(s) - chilled/frozen/multi-use	Frozen: -10°C ~ -25°C
EN	(where applicable) Heavy-duty/light-duty	Light Duty
EN	Refrigerant fluid(s): [information to identify the refrigerant fluid(s), including GWP]	R600a/ GWP 3

V / Hz	H x W x D	Kg
220-240V~ 50Hz	1890 x 777 x 705mm	94kg

Note: For optimal product performance and efficiency, please ensure to mind the net usable capacity (load limit) when filling.

	CD085-A				
EN	Annual Energy Consumption AEC (kWh)	989			
EN	Energy Efficiency Index EEI	26.1			
EN	Net volume Vn litre (where applicable)	469L			
EN	Chilled volume Vn Ref litre	N/A			
EN	Frozen volume Vn Frz litre	469L			
EN	Refrigerant charge x.xx kg	0.150kg			
EN	Power / Current	300W/ 1.4A			

Information requirements for professional refrigerated storage cabinets

Note: Due to our continuous improvement process, the product specifications are subject to change without notice.

EN	Model(s): [information identifying the model(s) to which the information relates]	GL185-A		
EN	Intended use	Storage	Category - Vertical/counter	Vertical
EN	Operating temperature(s) - chilled/frozen/multi-use		Chilled: -2°C ~ 8°C	
EN	(where applicable) Heavy-duty/light-duty	Light Duty		
EN	Refrigerant fluid(s): [information to identify the refrigerant fluid(s), including GWP]		R600a/ GWP 3	

V / Hz	H x W x D	Kg
220-240V~ 50Hz	1720 x 777 x 725mm	90kg

Note: For optimal product performance and efficiency, please ensure to mind the net usable capacity (load limit) when filling.

		GL185-A				
EN	Annual Energy Consumption AEC (kWh)	624				
EN	Energy Efficiency Index EEI	48.7				
EN	Net volume Vn litre (where applicable)	410L				
EN	Chilled volume Vn Ref litre	410L				
EN	Frozen volume Vn Frz litre	N/A				
EN	Refrigerant charge x.xx kg	0.095kg				
EN	Power / Current	130W/ 0.9A				

Note: Due to our continuous improvement process, the product specifications are subject to change without notice.

EN	Model(s): [information identifying the model(s) to which the information relates]		CD086-A
EN	Intended use	Storage	Category - Vertical/counter Vertical
EN	Operating temperature(s) - chilled/frozen/multi-use		Chilled: 2°C ~ 8°C
EN	(where applicable) Heavy-duty/light-duty	Light Duty	
EN	Refrigerant fluid(s): [information to identify the refrigerant fluid(s), including GWP]		R600a/ GWP 3
	V / Hz	H x W x D	Kg
	220-240V~ 50Hz	855 x 600 x 619mm	47kg

Note: For optimal product performance and efficiency, please ensure to mind the net usable capacity (load limit) when filling.

		CD086-A				
EN	Annual Energy Consumption AEC (kWh)	N/A				
EN	Energy Efficiency Index EEI	N/A				
EN	Net volume Vn litre (where applicable)	118L				
EN	Chilled volume Vn Ref litre	118L				
EN	Frozen volume Vn Frz litre	N/A				
EN	Refrigerant charge x.xx kg	0.035kg				
EN	Power / Current	105W/ 0.7A				

Note: Due to our continuous improvement process, the product specifications are subject to change without notice.

EN	Model(s): [information identifying the model(s) to which the information relates]		CD087-A
EN	Intended use	Storage	Category - Vertical/counter Vertical
EN	Operating temperature(s) - chilled/frozen/multi-use		Chilled: 2°C ~ 8°C
EN	(where applicable) Heavy-duty/light-duty	Light Duty	
EN	Refrigerant fluid(s): [information to identify the refrigerant fluid(s), including GWP]		R600a/ GWP 3
	V / Hz	H x W x D	Kg
	220-240V~ 50Hz	1855 x 600 x 620mm	72kg

Note: For optimal product performance and efficiency, please ensure to mind the net usable capacity (load limit) when filling.

		CD087-A				
EN	Annual Energy Consumption AEC (kWh)	N/A				
EN	Energy Efficiency Index EEI	N/A				
EN	Net volume Vn litre (where applicable)	246L				
EN	Chilled volume Vn Ref litre	246L				
EN	Frozen volume Vn Frz litre	N/A				
EN	Refrigerant charge x.xx kg	0.090kg				
EN	Power / Current	130W/ 0.8A				

Note: Due to our continuous improvement process, the product specifications are subject to change without notice.

EN	Model(s): [information identifying the model(s) to which the information relates]		CD088-A
EN	Intended use	Storage	Category - Vertical/counter Vertical
EN	Operating temperature(s) - chilled/frozen/multi-use		Chilled: 2°C ~ 8°C
EN	(where applicable) Heavy-duty/light-duty	Light Duty	
EN	Refrigerant fluid(s): [information to identify the refrigerant fluid(s), including GWP]		R600a/ GWP 3
	V / Hz	H x W x D	Kg
	220-240V~ 50Hz	1890 x 777 x 730mm	93kg

Note: For optimal product performance and efficiency, please ensure to mind the net usable capacity (load limit) when filling.

		CD088-A				
EN	Annual Energy Consumption AEC (kWh)	N/A				
EN	Energy Efficiency Index EEI	N/A				
EN	Net volume Vn litre (where applicable)	414L				
EN	Chilled volume Vn Ref litre	414L				
EN	Frozen volume Vn Frz litre	N/A				
EN	Refrigerant charge x.xx kg	0.110kg				
EN	Power / Current	130W/ 0.9A				

Note: Due to our continuous improvement process, the product specifications are subject to change without notice.

EN	Model(s): [information identifying the model(s) to which the information relates]		CB921-A
EN	Intended use	Storage	Category - Vertical/counter Vertical
EN	Operating temperature(s) - chilled/frozen/multi-use		Frozen: -10°C ~ -25°C
EN	(where applicable) Heavy-duty/light-duty	Light Duty	
EN	Refrigerant fluid(s): [information to identify the refrigerant fluid(s), including GWP]		R600a/ GWP 3
	V / Hz	H x W x D	Kg
	220-240V~ 50Hz	1855 x 600 x 620mm	76kg

Note: For optimal product performance and efficiency, please ensure to mind the net usable capacity (load limit) when filling.

		CB921-A				
EN	Annual Energy Consumption AEC (kWh)	N/A				
EN	Energy Efficiency Index EEI	N/A				
EN	Net volume Vn litre (where applicable)	340L				
EN	Chilled volume Vn Ref litre	N/A				
EN	Frozen volume Vn Frz litre	340L				
EN	Refrigerant charge x.xx kg	0.110kg				
EN	Power / Current	380W/ 2.5A				

DECLARATION OF CONFORMITY

• Conformanceverklaring • Déclaration de conformité • Konformitätserklärung • Dichiarazione di conformità •
• Declaración de conformidad

Equipment Type • Uitrustingstype • Type d'équipement • Gerätetyp • Tipo di apparecchiatura • Tipo de equipo			Model • Modèle • Modell • Modello • Modelo					
C-Series Fridge 1. Stainless Steel Under Counter 150Ltr 2. Stainless Steel Upright 400Ltr 3. Stainless Steel Upright 600Ltr 4. White Under Counter 150Ltr 5. White Upright 400Ltr 6. White Upright 600Ltr	C-Series Freezer 7. Stainless Steel Under Counter 140Ltr 8. Stainless Steel Upright 365Ltr 9. Stainless Steel Upright 600Ltr 10. White Under Counter 140Ltr 11. White Upright 365Ltr 12. White Upright 600Ltr	C-Series Display 13. White Under Counter Fridge 150Ltr 14. White Upright Fridge 400Ltr 15. White Upright Fridge 600Ltr 16. White Upright Freezer 365Ltr	1. CD080 2. CD082 3. CD084 4. CD610 5. CD612 6. CD614	7. CD081 8. CD083 9. CD085 10. CD611 11. CD613 12. CD615 (including -E & -A models)	13. CD086 14. CD087 15. CD088 16. CB921			
Application of Territory Legislation & Council Directives(s) Toepassing van Europese Richtlijn(en) • Application de la/des directive(s) du Conseil • Anwendbare EU-Richtlinie(n) • Applicazione delle Direttive • Aplicación de la(s) directiva(s) del consejo			Machinery Directive 2006/42/EC Supply of Machinery (Safety) Regulations 2008 EN 60335-1:2012 +A11:2014 +A13:2017 +A1:2019 +A14:2019 +A2:2019 EN 60335-2-89:2010 +A1:2016 +A2:2017 EN62233:2008 Electro-Magnetic Compatibility (EMC) Directive 2014/30/EU - recast of 2004/108/EC Electromagnetic Compatibility Regulations 2016 (S.I. 2016/1091) EN IEC 55014-1: 2021 EN IEC 55014-2: 2021 EN IEC 61000-3-2: 2019+A1:2021 EN 61000-3-3: 2013+A1:2019+A2: 2021 Regulation (EU) 2015/1095 - Ecodesign professional refrigerators EN 16825: 2016 +A1:2019 Regulation (EU) 2019/2024 - Ecodesign direct sales refrigerators ISO 23953-2:2015 Restriction of Hazardous Substances Directive (RoHS) 2015/863 amending Annex II to Directive 2011/65/EU Restriction of the Use of Certain Hazardous Substances in Electrical and Electronic Equipment Regulations 2012 (S.I. 2012/3032)			Electrical Safety IEC 60335.1:2010 +A1:2013 +A2:2016 IEC 60335-2-89:2010 +A1:2012 +A2:2015 Electromagnetic Compatibility EN IEC 55014-1: 2021 EN IEC 55014-2: 2021 EN IEC 61000-3-2: 2019+A1:2021 EN 61000-3-3: 2013+A1:2019+A2: 2021		
Manufacturer Name • Naam fabrikant • Nom du fabricant • Name des Herstellers • Nome del fabbricante • Nombre del fabricante			Polar					

I, the undersigned, hereby declare that the equipment specified above conforms to the above Territory Legislation, Directive(s) and Standard(s).

Ik, de ondergetekende, verklaar hierbij dat de hierboven gespecificeerde uitrusting goedgekeurd is volgens de bovenstaande Richtlijn(en) en Standaard(en).

Je soussigné, confirme la conformité de l'équipement cité dans la présente à la / aux Directive(s) et Norme(s) ci-dessus

Ich, der/die Unterzeichnende, erkläre hiermit, dass das oben angegebene Gerät der/den oben angeführten Richtlinie(n) und Norm(en) entspricht.

Il sottoscritto dichiara che l'apparecchiatura di sopra specificata è conforme alle Direttive e agli Standard sopra riportati.

El abajo firmante declara por la presente que el equipo arriba especificado está en conformidad con la(s) directiva(s) y estándar(es) arriba mencionadas.

Date • Data • Date • Datum • Data •

Fecha

Signature • Handtekening •

Signature • Unterschrift Firma •

Firma

Full Name • Volledige naam • Nom et prénom

• Vollständiger Name • Nome completo •

Nombre completo

Position • Functie • Fonction • Position •

Qualifica • Posición

Manufacturer Address • Adres fabrikant •

Adresse du fabricant • Adresse des Herstellers

• Indirizzo del fabbricante • Dirección del

fabricante

18th Jun 2024

DocuSigned by:

Ashley Hooper

B39382C9FD9C478...

Ashley Hooper

DocuSigned by:

Eoghan Donnellan

D352874F7FAB460...

Eoghan Donnellan

DocuSigned by:

Brendan

386FAD00DFE8483...

Brendan Denmeade

Group Head of Product
Quality & Compliance

Commercial Manager/
Importer

Commercial Manager/
Responsible Supplier

Fourth Way,
Avonmouth,
Bristol,
BS11 8TB
United Kingdom

Unit 9003,
Blarney Business Park,
Blarney,
Co. Cork
Ireland

15 Badgally Road,
Campbelltown
NSW 2560



POLAR



<http://www.polar-refrigerator.com/> 

CD610-A to CD615-A_CD080-A to CD088-A_CB921-A_GL185-A_A5_v14_2024/08/20