



Display Fridge

Instruction manual



Model

CZ785-A/CZ786-A/CZ787-A

Safety Instructions

- Position on a flat, stable surface.
- A service agent/qualified technician should carry out installation and any repairs if required. Do not remove any components or service panels on this product.
- **- In Queensland the service agent/qualified technician MUST hold a Gas Work Authorisation or License for hydrocarbon refrigerants if the appliance gas system is being opened or charged.**
- Consult Local and National Standards to comply with the following:
 - Health and Safety at Work Legislation
 - Fire Precautions
 - IEE Wiring Regulations
 - Building Regulations
- DO NOT use jet/pressure washers to clean the appliance.
- DO NOT use the appliance outside.
- DO NOT use this appliance to store medical supplies.
- DO NOT allow oil or fat to come into contact with the plastic components or door seal. Clean immediately if contact occurs.
- DO NOT store products on top of the appliance.
- Bottles that contain a high percentage of alcohol must be sealed and placed vertically in the refrigerator.
- Always carry, store and handle the appliance in a vertical position and move by holding the base of the appliance.
- Always switch off and disconnect the power supply to the unit before cleaning.
- Keep all packaging away from children. Dispose of the packaging in accordance with the regulations of local authorities.
- If the power cord is damaged, it must be replaced by a POLAR agent or a recommended qualified technician in order to avoid a hazard.

- Children should be supervised to ensure that they do not play with the appliance.
- This appliance is not intended for use by persons (including children) with reduced physical, sensory or mental capabilities, or lack of experience or knowledge, unless they have been given supervision or instruction concerning the use of the appliance by a person responsible for their safety.
- POLAR recommend that this appliance should be periodically tested (at least annually) by a Competent Person. Testing should include, but not be limited to: Visual Inspection, Polarity Test, Earth Continuity, Insulation Continuity and Functional Testing.

Caution: Risk of Fire



- Do not store explosive substances such as aerosol cans with a flammable propellant in this appliance.



Warning: Keep all ventilation openings clear of obstruction. Unit should not be boxed in without adequate ventilation.

- **To comply with AS/NZS 60079.10.1:2009: Ensure there are not sources of ignition in any area where refrigerant could gather in the event of a leak.**
- **Electrical equipment should not be placed under the vent or where refrigerant could gather in the event of a leak.**
- **Warning:** Do not use mechanical devices or other means to accelerate the defrosting process, other than those recommended by the manufacturer.
- **Warning:** Do not damage the refrigerant circuit.
- **Warning:** Do not use electrical appliances inside the food storage compartments of the appliance.

Introduction

Please take a few moments to carefully read through this manual. Correct maintenance and operation of this machine will provide the best possible performance from your POLAR product.

Pack Contents

The following is included:

- POLAR Display Fridge
- Shelves
CZ785-A x 3
CZ786-A/CZ787-A x 4
- Keys x 2
- Spacers x 2
- Instruction Manual

POLAR prides itself on quality and service, ensuring that at the time of unpacking the contents are supplied fully functional and free of damage.

Should you find any damage as a result of transit, please contact your POLAR dealer immediately.

Installation

Note: A bracket is used to support the door during transportation. On receipt please remove the bracket.

Note: Not for use in vans or trailers, food trucks or similar vehicles.

If the unit has not been stored or moved in an upright position, let it stand upright for approximately 12 hours before operation. If in doubt allow to stand.

1. Remove the appliance from the packaging. Make sure that all protective plastic film and coatings are thoroughly removed from all surfaces.
2. To optimize performance and longevity, ensure a minimum clearance of 2.5cm is maintained between the unit and walls and other objects, with a minimum 20cm clearance on the top. **NEVER LOCATE NEXT TO A HEAT SOURCE.**

Note: Before using the appliance for the first time, clean the shelves and interior with soapy water then dry well.

The appliance is supplied with feet by default. However, castors can be supplied as an option.

Mounting the door handle

1. Pull the door gasket aside to expose the 2 pre-drilled holes. Insert the screws.
2. Mount sleeve on the other end of screw. Tighten screws to fix the handle in place.

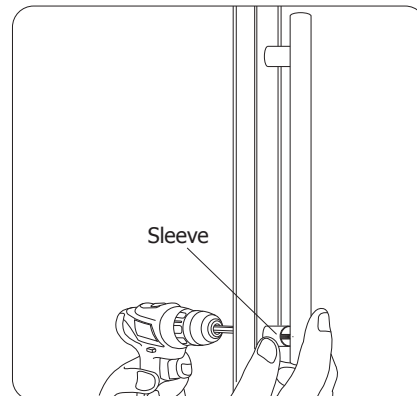
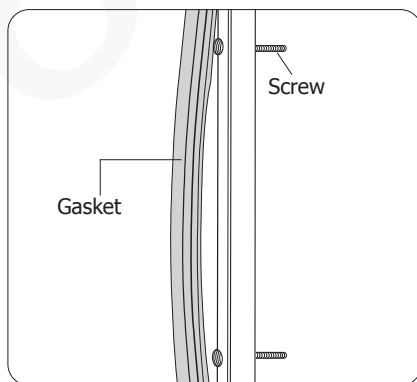

Reversing the door

Depending on the location of the appliance, it may be necessary to change the direction the door opens by changing the side of the door handle. (Tip: Images in this section are for illustration only and may slightly differ from the actual appliance appearances.)

To reverse the door handle:

1. The door handle is on the left side. Disassemble the right lower hinge.

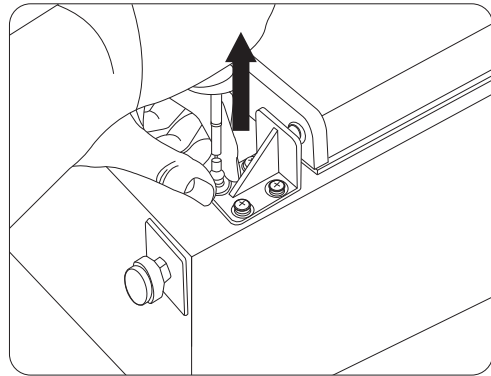
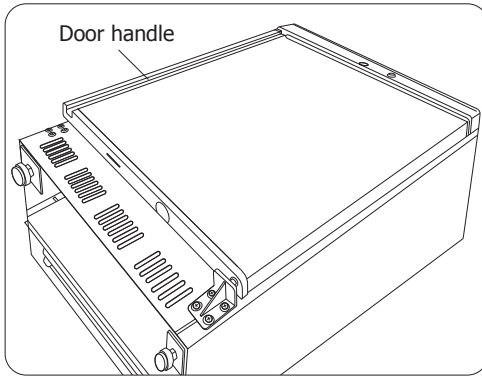

2. Remove the door from the right upper hinge. Then remove the hinge sleeve from the door top.

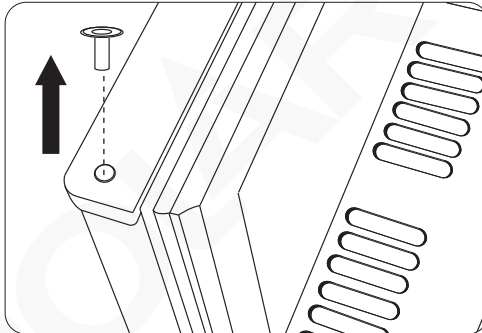

3. Remove the right upper hinge and install it on the left side. Afterwards, install the hinge sleeve onto the hinge.

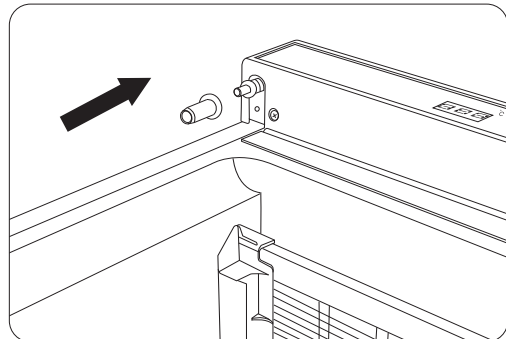
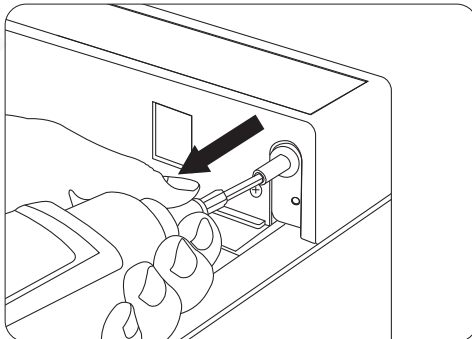

4. Reverse the door and hang it onto the left upper hinge.

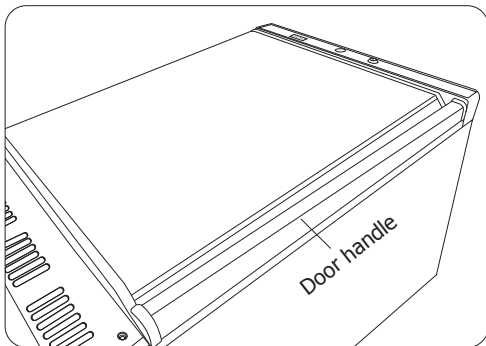

7. Secure the hinge in place using the previously removed screws.

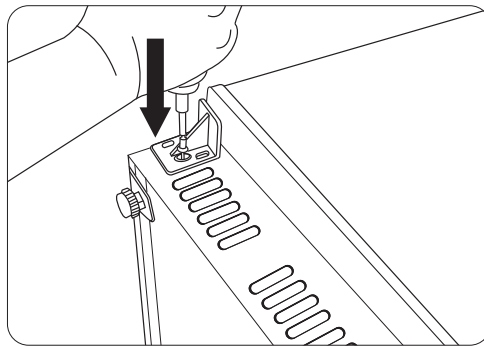

5. Remove the pre-mounted screws on the left lower side.

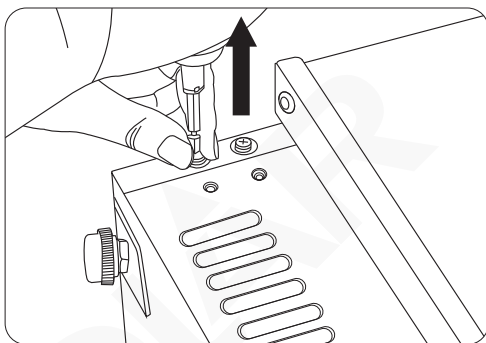

8. Now the door handle is installed on the right side.

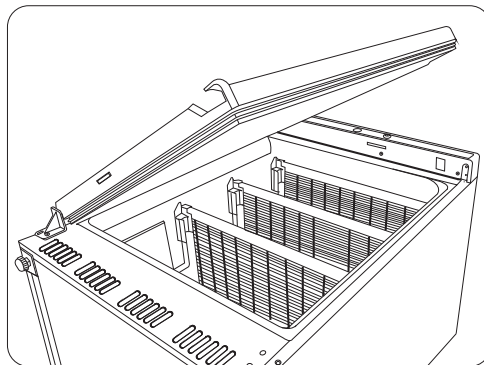

6. Install the previously removed right lower hinge on the left side.

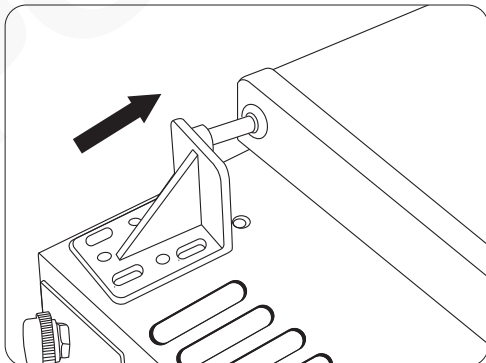

Operation

Control Panel

The control panel is located on the front of the appliance.

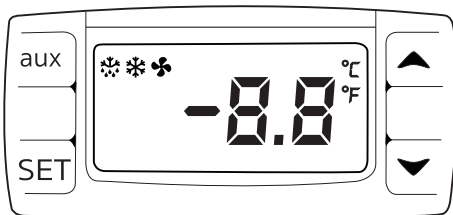

Turn On

1. Close the door of the appliance.
2. Connect the appliance to a mains power supply.

Set the Operating Temperature

1. Press the **SET** button for 3 seconds. The display will flash.
2. Press the ▲ or ▼ buttons to display the required temperature.
3. Press the **SET** button to store the temperature.

Manual Defrost

Press and hold the defrost button "aux" for 2 seconds to begin a manual defrost. The defrost light illuminates. The defrost cycle will end automatically.

Storing Food

To get the best results from your POLAR appliance, follow these instructions:

- Only store foodstuffs in the appliance when it has reached the correct operating temperature.
- Do not place uncovered items as below inside the appliance, as this can lead to a damaged and leaking evaporator, and thus void your warranty: hot food, hot liquids, acidic fluids, acidic products.
- Wrap or cover food where possible.
- Do not obstruct the fans inside the appliance.
- Avoid opening the doors for prolonged periods of time.

Lock/Unlock the Doors

- A lock is fitted to the doors to ensure foodstuffs are kept secure within your POLAR appliance.
- Use the keys provided to lock/unlock the door.

Cleaning, Care & Maintenance

- Switch off and disconnect from the power supply before cleaning.
- Clean the interior of the appliance as often as possible.
- Do not use abrasive cleaning agents. These can leave harmful residues.
- Clean the door seal with warm soapy water.
- Always wipe dry after cleaning.
- Do not allow water used in cleaning to run through the drain hole into the evaporation pan.
- Take care when cleaning the rear of the appliance. Sharp edges can cut.

Refrigerating tips:

- Condensation and ice will form with frequent and prolonged opening of the doors.
- Operating outside of the recommend temperature range and placing next to a heat source will also increase the amount of ice and internal/external condensation. If external condensation occurs wipe the surface down with a cloth.
- Excessive ice will result in longer running times that will increase energy consumption and increase the deterioration of components.
- If the gasket or seal is damaged or deformed, energy consumption will increase. To restore efficiency, replace gasket.
- Do not obstruct fans and do not exceed max load lines, as doing so will impact air distribution and increase energy usage.

Cleaning the Condenser

Periodically cleaning the condenser can extend the life of the appliance. POLAR recommend that a POLAR agent or qualified technician should clean the condenser.

Failure to clean the condenser will increase energy consumption, reduce the performance and life of your Polar unit, and thus may invalidate your warranty.

Troubleshooting

A qualified technician must carry out repairs if required.

Fault	Probable Cause	Solution
The appliance is not working	The unit is not switched on	Check the unit is plugged in correctly and switched on
	Plug or lead is damaged	Replace Plug or lead
	Mains power supply fault	Check mains power supply
The appliance turns on, but the temperature is too high/low	Too much ice on the evaporator	Defrost the appliance
	Condenser blocked with dust	Clean the condenser
	Doors are not shut properly	Check doors are shut and seals are not damaged
	Appliance is located near a heat source or air flow to the condenser is being interrupted	Move the refrigerator to a more suitable location
	Ambient temperature is too high	Increase ventilation or move appliance to a cooler position
	Unsuitable foodstuffs are being stored in the appliance	Remove any excessive hot foodstuffs or blockages to the fan
	Appliance is overloaded	Reduce the amount of food stored in the appliance
The appliance is leaking water	The appliance is not properly levelled	Adjust the screw feet to level the appliance (if applicable)
	The discharge outlet is blocked	Clear the discharge outlet
The appliance is leaking water	Movement of water to the drain is obstructed	Clear the floor of the appliance (if applicable)
	The water container is damaged	Consult a qualified Technician
	The drip tray is overflowing	Empty the drip tray (if applicable)
The appliance is unusually loud	Loose nut/screw	Check and tighten all nuts and screws
	The appliance has not been installed in a level or stable position	Check installation position and change if necessary
Display lamp does not light	Lamp needing replacing	Consult a qualified Technician

Technical Specifications

Note: Due to our continuous improvement process, the product specifications are subject to change without notice.

Model	Voltage	Power	Current	Temperature Range	Gross Capacity (L)	Net usable capacity (L)	Refrigerant type / weight (kg)	Dimensions H x W x D mm	Weight (kg)
CZ785-A	220-240V~ 50Hz	100W	0.5A	0°C ~ 8°C	150	66	R600a (0.050kg)	855 x 600 x 635	47
CZ786-A		115W	0.5A	0°C ~ 8°C	400	239	R600a (0.070kg)	1855 x 600 x 635	72
CZ787-A		115W	0.5A	0°C ~ 8°C	600	428	R600a (0.070kg)	1895 x 777 x 745	93

Note: For optimal product performance and efficiency, please ensure to mind the net usable capacity (load limit) when filling.

Electrical Wiring

The plug is to be connected to a suitable mains socket.

POLAR appliances are wired as follows:

- Live wire (coloured brown) to terminal marked L
- Neutral wire (coloured blue) to terminal marked N
- Earth wire (coloured green/yellow) to terminal marked E

This appliance must be earthed.



If in doubt consult a qualified electrician.

Electrical isolation points must be kept clear of any obstructions. In the event of any emergency disconnection being required they must be readily accessible.

Compliance

The product must not be disposed of as household waste. To help prevent possible harm to human health and/or the environment, the product must be disposed of in an approved and environmentally safe recycling process. For further information on how to dispose of this product correctly, contact the product supplier, or the local authority responsible for waste disposal in your area.

POLAR parts have undergone strict product testing in order to comply with regulatory standards and specifications set by international, independent, and federal authorities.

POLAR products have been approved to carry the following symbol:



All rights reserved. No part of these instructions may be produced or transmitted in any form or by any means, electronic, mechanical, photocopying, recording or otherwise, without the prior written permission of POLAR.

Every effort is made to ensure all details are correct at the time of going to press, however, POLAR reserve the right to change specifications without notice.

DECLARATION OF CONFORMITY

• Conformiteitsverklaring • Déclaration de conformité • Konformitätserklärung • Dichiarazione di conformità •
• Declaración de conformidad

Equipment Type • Uitrustingstype • Type d'équipement • Gerätetyp • Tipo di apparecchiatura • Tipo de equipo	Model • Modèle • Modell • Modello • Modelo	
C-Series Under Counter Display Fridge White - 150Ltr C-Series Upright Display Fridge White - 400Ltr C-Series Upright Display Fridge White - 600Ltr	CZ785 (-E & -A) CZ786 (-E & -A) CZ787 (-E & -A)	
Application of Territory Legislation & Council Directives(s) Toepassing van Europese Richtlijn(en) • Application de la/des directive(s) du Conseil • Anwendbare EU-Richtlinie(n) • Applicazione delle Direttive • Aplicación de la(s) directiva(s) del consejo	Machinery Directive 2006/42/EC Supply of Machinery (Safety) Regulations 2008 EN 60335-1:2012 +A11:2014 +A13:2017 +A1:2019 +A14:2019 +A2:2019 +A15:2021 EN 60335-2-89:2010 +A1:2016 +A2:2017 EN62233:2008 Electro-Magnetic Compatibility (EMC) Directive 2014/30/EU - recast of 2004/108/EC Electromagnetic Compatibility Regulations 2016 (S.I. 2016/1091) EN IEC 55014-1: 2021 EN IEC 55014-2: 2021 EN IEC 61000-3-2: 2019+A1:2021 EN 61000-3-3: 2013+A1:2019+A2: 2021 Restriction of Hazardous Substances Directive (RoHS) 2015/863 amending Annex II to Directive 2011/65/EU Restriction of the Use of Certain Hazardous Substances in Electrical and Electronic Equipment Regulations 2012 (S.I. 2012/3032)	Electrical Safety IEC 60335-1:2010 +A1:2013 +A2:2016 IEC 60335-2-89:2010 +A1:2012 +A2:2015 Electromagnetic Compatibility EN IEC 55014-1:2021 EN IEC 55014-2: 2021 EN IEC 61000-3-2:2019+A1:2021 EN 61000-3-3:2013+A1:2019+A2: 2021
Manufacturer Name • Naam fabrikant • Nom du fabricant • Name des Herstellers • Nome del fabbricante • Nombre del fabricante	Polar	

I, the undersigned, hereby declare that the equipment specified above conforms to the above Territory Legislation, Directive(s) and Standard(s).

Ik, de ondergetekende, verklaar hierbij dat de hierboven gespecificeerde uitrusting goedgekeurd is volgens de bovenstaande Richtlijn(en) en Standaard(en).

Je soussigné, confirme la conformité de l'équipement cité dans la présente à la / aux Directive(s) et Norme(s) ci-dessus

Ich, der/die Unterzeichnende, erkläre hiermit, dass das oben angegebene Gerät der/den oben angeführten Richtlinie(n) und Norm(en) entspricht.

Il sottoscritto dichiara che l'apparecchiatura di sopra specificata è conforme alle Direttive e agli Standard sopra riportati.



El abajo firmante declara por la presente que el equipo arriba especificado está en conformidad con la(s) directiva(s) y estándar(es) arriba mencionadas.

Date • Data • Date • Datum • Data •
 Fecha
 Signature • Handtekening •
 Signatura • Unterschrift Firma •
 Firma

Full Name • Volledige naam • Nom et prénom • Vollständiger Name • Nome completo • Nombre completo

Position • Functie • Fonction •
 Position • Qualifica • Posición

Manufacturer Address • Adres fabrikant • Adresse du fabricant • Adresse des Herstellers • Indirizzo del fabbricante • Dirección del fabricante

08 th Jul 2024		
DocuSigned by:  B39382C9FD9C478...	DocuSigned by:  D352674F7FAB460...	DocuSigned by:  386FAD00DFE8483...
Ashley Hooper	Eoghan Donnellan	Brendan Denmeade
Group Head of Product Quality & Compliance	Commercial Manager/Importer	Commercial Manager/Responsible Supplier
Fourth Way, Avonmouth, Bristol, BS11 8TB United Kingdom	Unit 9003, Blarney Business Park, Blarney, Co. Cork Ireland	15 Badgally Road, Campbelltown NSW 2560



POLAR

POLAR



<http://www.polar-refrigerator.com/> 

CZ785-A-CZ786-A-CZ787-A_A5_v1_2024/12/04